

Key Features:

- High efficiency
- High performance
- Easily interfaced
- Durable moving body design
- Flow reversed for anchor recovery

Tritech AnchorZip 10

Pumps and Water Jetters

The Trittech AnchorZip 10 is a unique product which has been developed using the highly successful ZipPump and ZipJet technologies.

The AnchorZip 10 is a heavy duty suction anchor pump designed for work-class vehicles able to produce 25hp of hydraulic power. The AZ10 will offer a very quick and cost effective way of installing and removing suction anchors. Output pressures may be regulated to ensure that differential pressures remain within the structural limits of all types of suction anchor.

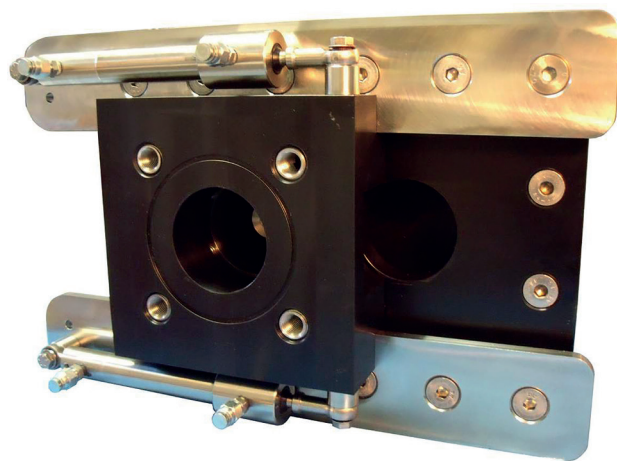

Tritech AnchorZip 10

Pumps and Water Jetters



Specifications

Dimensions	Length	452mm
	Width	290mm
Weight	Weight in air	30Kg
	Weight in water	14Kg
Hydraulic Motor Input	Pressure	276 Bar
	Flow	70 LPM
Actuator	Minimum pressure	70 Bar
	Maximum pressure	240 Bar
Output	Typical differential pressure	Up to 9.5 Bar
	Typical suction flow	Up to 80 cubic metres per hour at 7.5 Bar

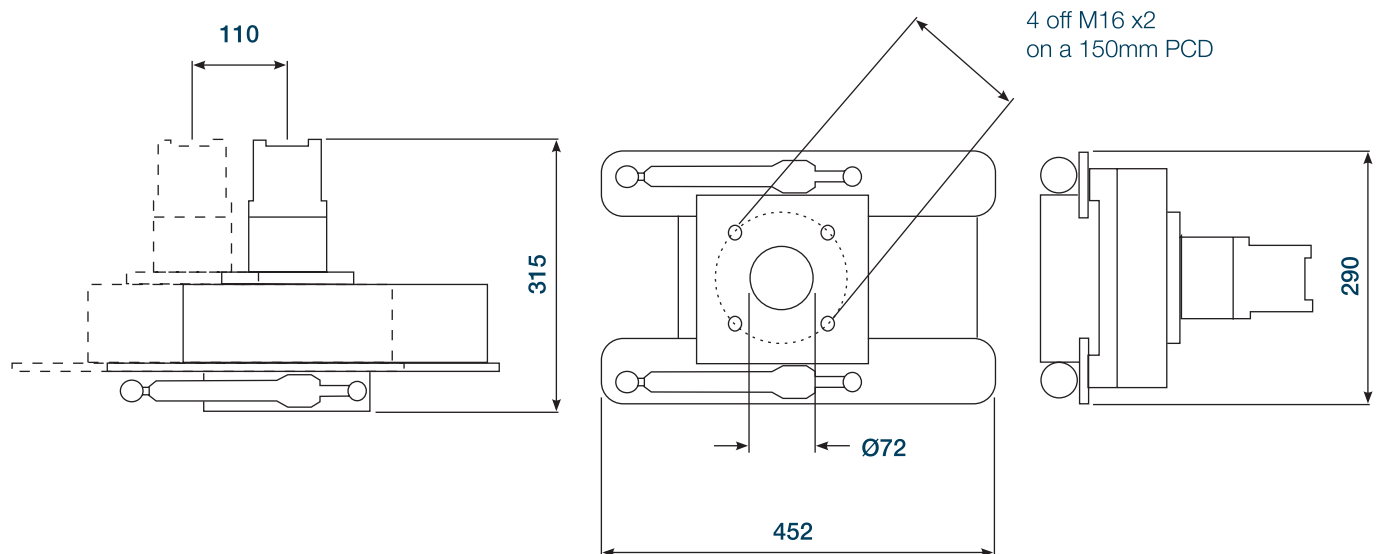

System Components

AZ10 anchor pump		
Operating manual		
Transit case		
Suction hose		