

Key Features:

- Hydraulic clamp & auto feed
- Models available to cut 6" - 84" OD pipe
- Powerful hydraulic drive wheel
- ROV and diver compatible
- Strong aluminium frame

Mirage Diamond Wire Cutter

Cutters and Grinders

The Mirage Diamond Wire Saw (MDWS) is designed for underwater cutting on multistring casings, piles, platform legs and wellhead. The diamond wire cut is ideal for quick cutting through dissimilar materials and resisting compressive forces.

MDWS is an abrasive cutting technology that is extremely effective in different subsea environments. The wire cutter allows circular cutting on all sides, preventing the wire from getting pinched on materials that would otherwise damage lathe and mill type tooling. Customized saws are available by special order.

While the machine can be used topside, it is not considered a cold cutting method when used for surface operations.

The machine is supplied complete with packing list and manual. Optional accessories include: three function hydraulic control panel, hydraulic power unit, six pass hydraulic hose reels and spares kit. ROV operating and hot stab packages.

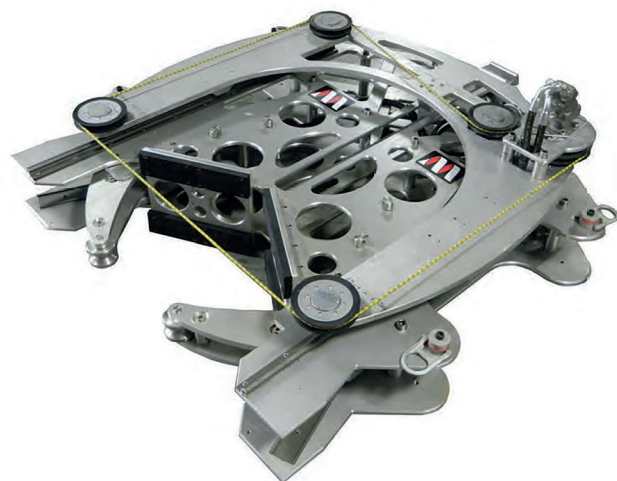

Mirage Diamond Wire Cutter

Cutters and Grinders



Specifications

		MDWS620	MDWS1638	MDWS3660	MDW6084
Dimensions	Length	2159mm	2590mm	3632mm	4572mm
	Width	1524mm	1905mm	2667mm	3606mm
	Height	762mm	762mm	762mm	762mm
Weight	Weight in air	413Kg	566Kg	855Kg	1036Kg
	Weight in water	235Kg	269Kg	536Kg	746Kg
Cutting Capacity		152-508mm	406-965mm	914-1524mm	1422-2032mm
Feed Stroke		660mm	1117mm	1676mm	2286mm

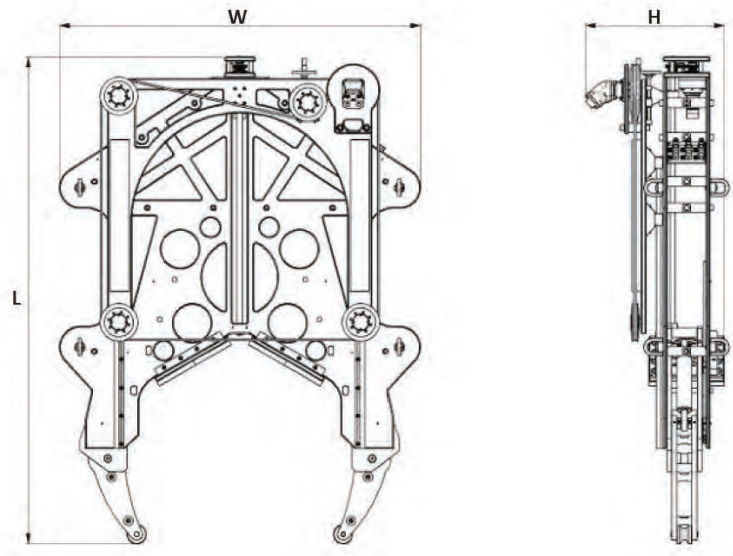

System Components
